

DO NOT
SCALE FROM
THIS PRINT

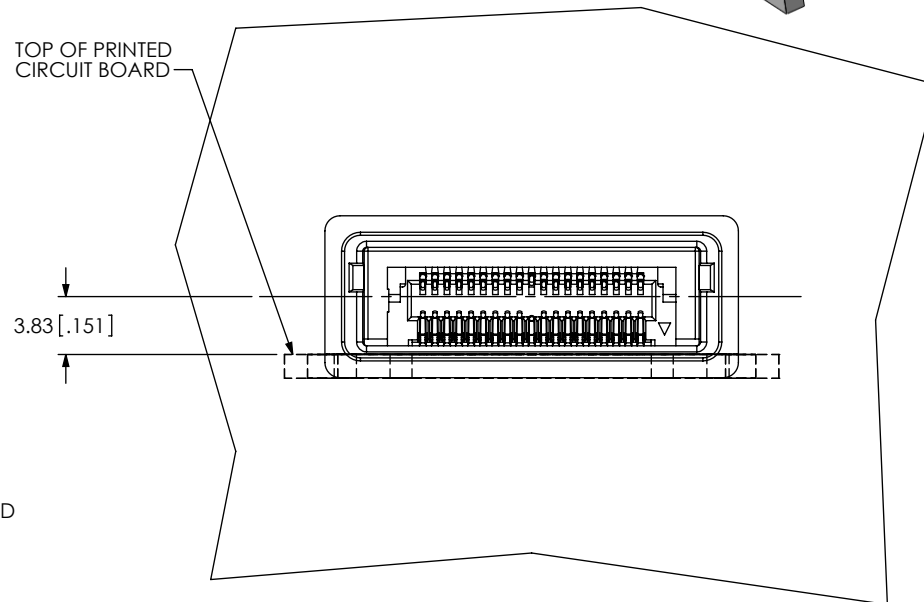
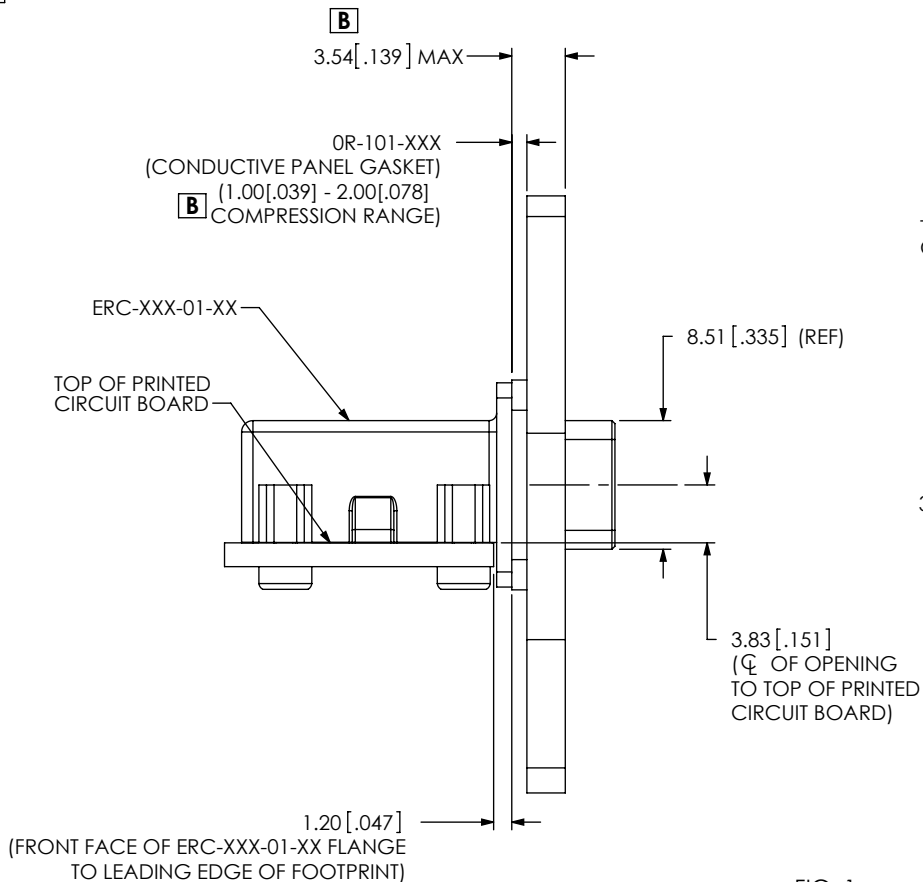
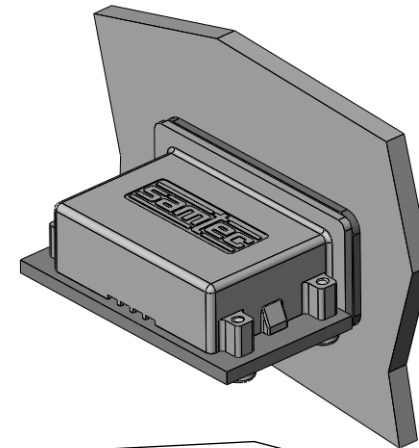

FIG. 1
(ERC-XXX-01-02 ASSEMBLED TO PANEL)
(WITH GASKET)

NOTES:

1. $\text{\textcircled{C}}$ REPRESENTS A CRITICAL DIMENSION.

UNLESS OTHERWISE SPECIFIED,
DIMENSIONS ARE IN MILLIMETERS [INCHES].

TOLERANCES ARE:

DECIMALS ANGLES
.X: ± 0.3 [.01] 2°
.XX: ± 0.13 [.005]
.XXX: ± 0.051 [.0020]

PROPRIETARY NOTE

THIS DOCUMENT CONTAINS INFORMATION
CONFIDENTIAL AND PROPRIETARY TO
SAMTEC, INC. AND SHALL NOT BE REPRODUCED
OR TRANSFERRED TO OTHER DOCUMENTS OR
DISCLOSED TO OTHERS OR USED FOR ANY
PURPOSE OTHER THAN THAT WHICH IT WAS
OBTAINED WITHOUT THE EXPRESSED WRITTEN
CONSENT OF SAMTEC, INC.



520 PARK EAST BLVD, NEW ALBANY, IN 47150
PHONE: 812-944-6733 FAX: 812-948-5047
e-Mail: info@SAMTEC.com code: 55322

MATERIAL: DO NOT SCALE DRAWING SHEET SCALE: 2:1

DESCRIPTION:
ER18 APPLICATIONS, EDGE RATE I/O CONN SYSTEM

DWG. NO.
ER18 APPLICATIONS

BY: KNOWLDEN 5/8/2007 SHEET 1 OF 2

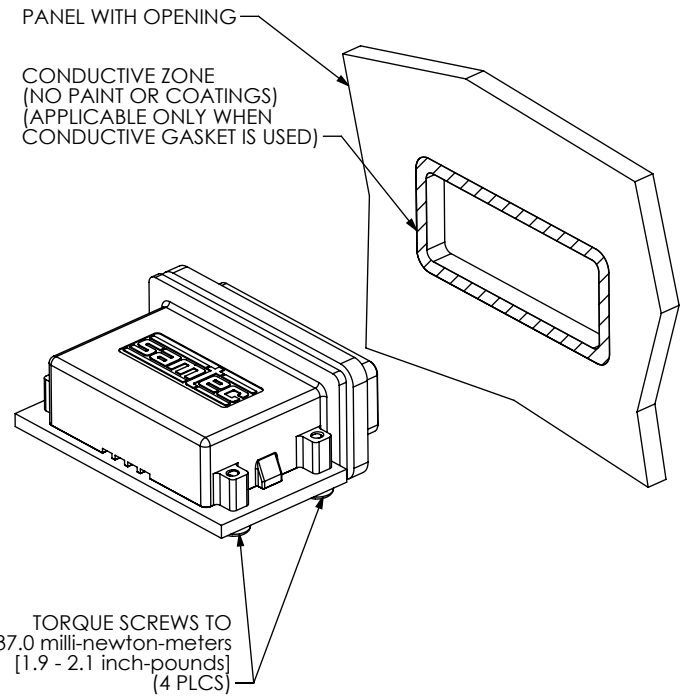
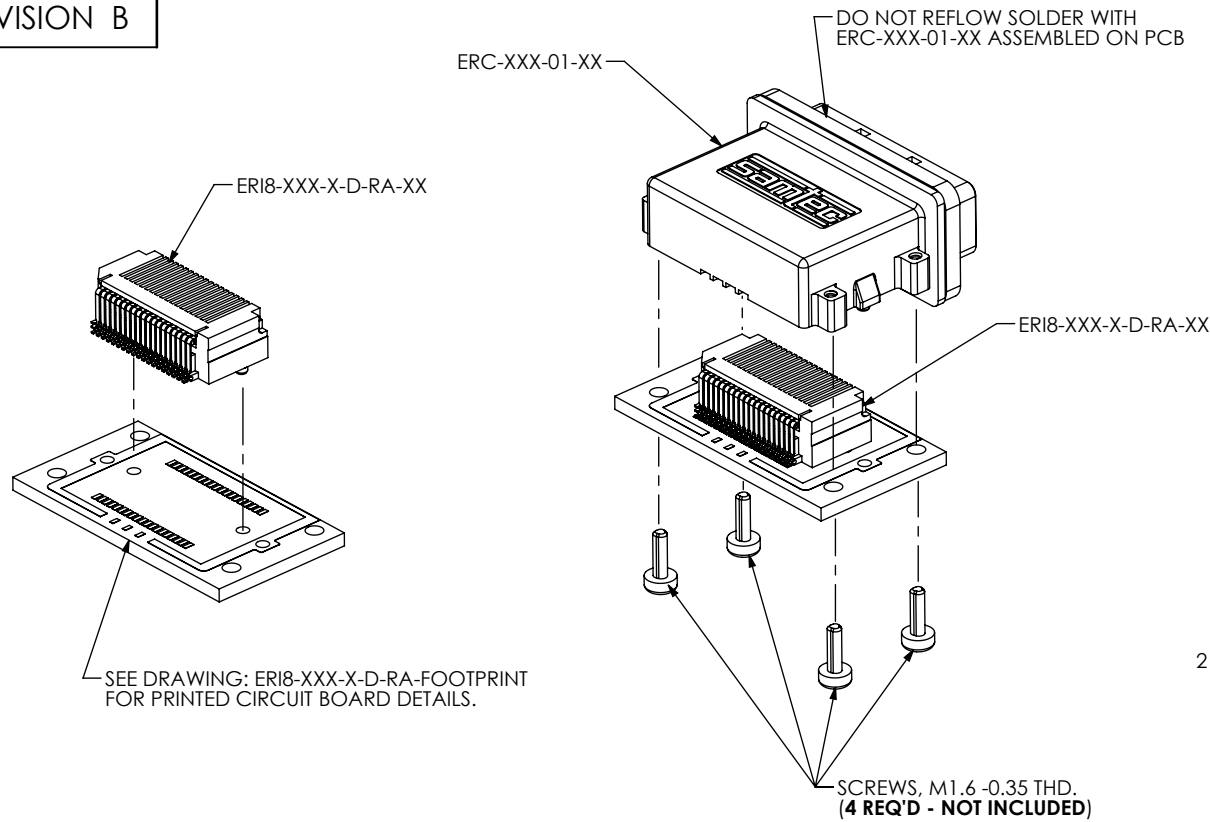

RECOMMENDED PANEL OPENING

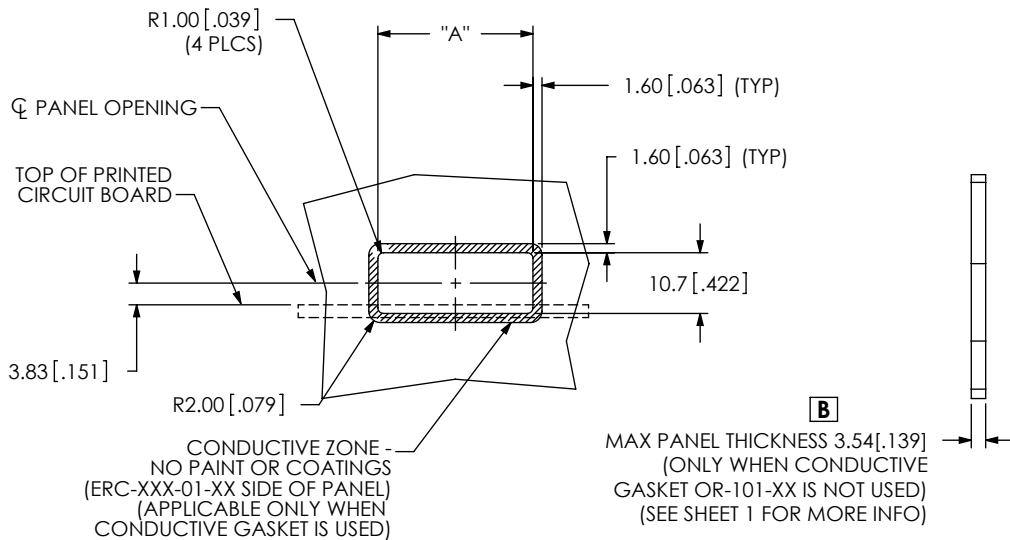

STYLE	"A"	
ERC-019-01-XX	27.3	[1.07]
ERC-031-01-XX	36.9	[1.45]

PROPRIETARY NOTE
 THIS DOCUMENT CONTAINS INFORMATION CONFIDENTIAL AND PROPRIETARY TO SAMTEC, INC. AND SHALL NOT BE REPRODUCED OR TRANSFERRED TO OTHER DOCUMENTS OR DISCLOSED TO OTHERS OR USED FOR ANY PURPOSE OTHER THAN THAT WHICH IT WAS OBTAINED WITHOUT THE EXPRESSED WRITTEN CONSENT OF SAMTEC, INC.

DO NOT SCALE DRAWING

SHEET SCALE: 2:1



520 PARK EAST BLVD, NEW ALBANY, IN 47150
 PHONE: 812-944-6733 FAX: 812-948-5047
 e-Mail: info@SAMTEC.com code: 55322

DESCRIPTION:
 ERI8 APPLICATIONS, EDGE RATE I/O CONN SYSTEM

DWG. NO. **ERI8 APPLICATIONS**

BY: KNOWLDEN 5/8/2007

SHEET 2 OF 2